

# LCC Modelling System

B 70-11 O gauge small engine shed with water tank

All drawings are not in scale. Some proportions on drawings may differ from reality.

For additional elements for modification and extension please visit our website at [www.lcut.co.uk](http://www.lcut.co.uk) or email us at [contact@lcut.co.uk](mailto:contact@lcut.co.uk)

Building footprint: 323mm x 126mm

Bundle contains:

- 1x LCC 00-02
- 2x LCC 70-00
- 2x LCC 70-01
- 1x LCC 70-09
- 1x LCC 70-06A
- 1x LCC 70-06B
- 2x LCC 70-17
- 1x LCC 74-00
- 1x LCC 74-02
- 1x LCC 74-03
- 6x LCC 74-06
- 1x LCC 74-08
- 3x LCC 74-09
- 3x LCC 74-10
- 4x LCC 74-11
- 2x LCC 74-12
- 1x LCC 74-12L
- 1x LCC 74-13
- 2x LCC 74-14
- 2x LCC 74-15
- 2x LCC 74-16
- 2x LCC 74-17
- 1x LCC 74-18
- 6x LCC 74-49
- 1x LCC 74-51
- 1x LCC 74-89
- 2x LCC 74-90
- 4x LCC 74-91S
- 2x LCC 74-92S
- 1x LCC 74-102



We recommend PVA or any other paper/wood glue for the main fibre board parts and resin based glue for 3D printed parts if present.

Painting recommendation:

We recommend using acrylic or enamel paints. There is no need to undercoat the surface but it can be done if desired. The material used is porous and relatively forgiving, heavy coats are unlikely to flood the brickwork. If you experience any warping in the material leave it to fully dry and then gently bend it back into shape. Always test any paints in an area that will not be seen or on spare parts/off cuts.

## WINDOWS, DOORS, GATES, AND WATER TANK

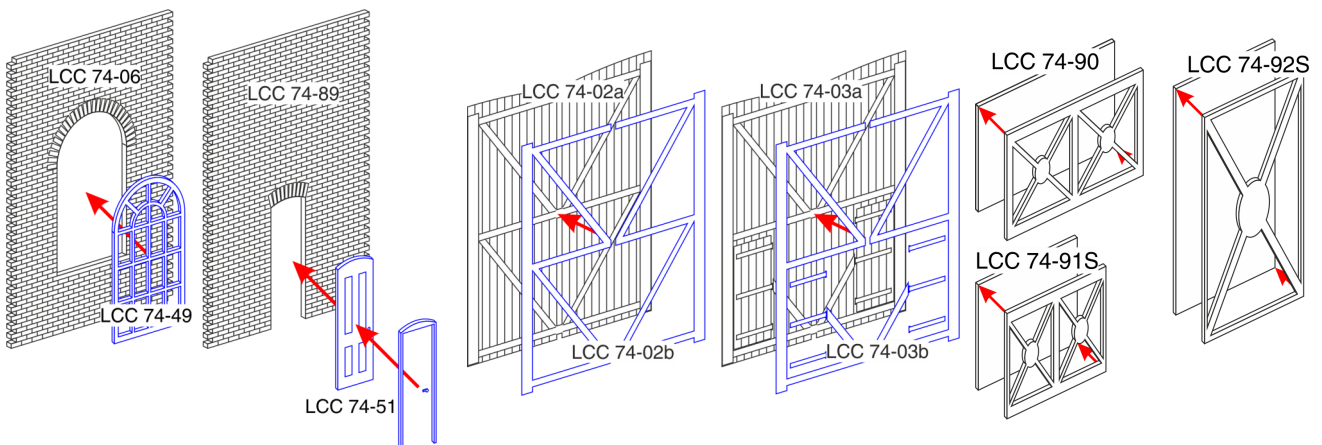

Windows and doors should be positioned flush with the back of wall panels. Depending on painting style it may be better to paint the windows and doors separately before gluing them into wall panels.

### ELEVATIONS

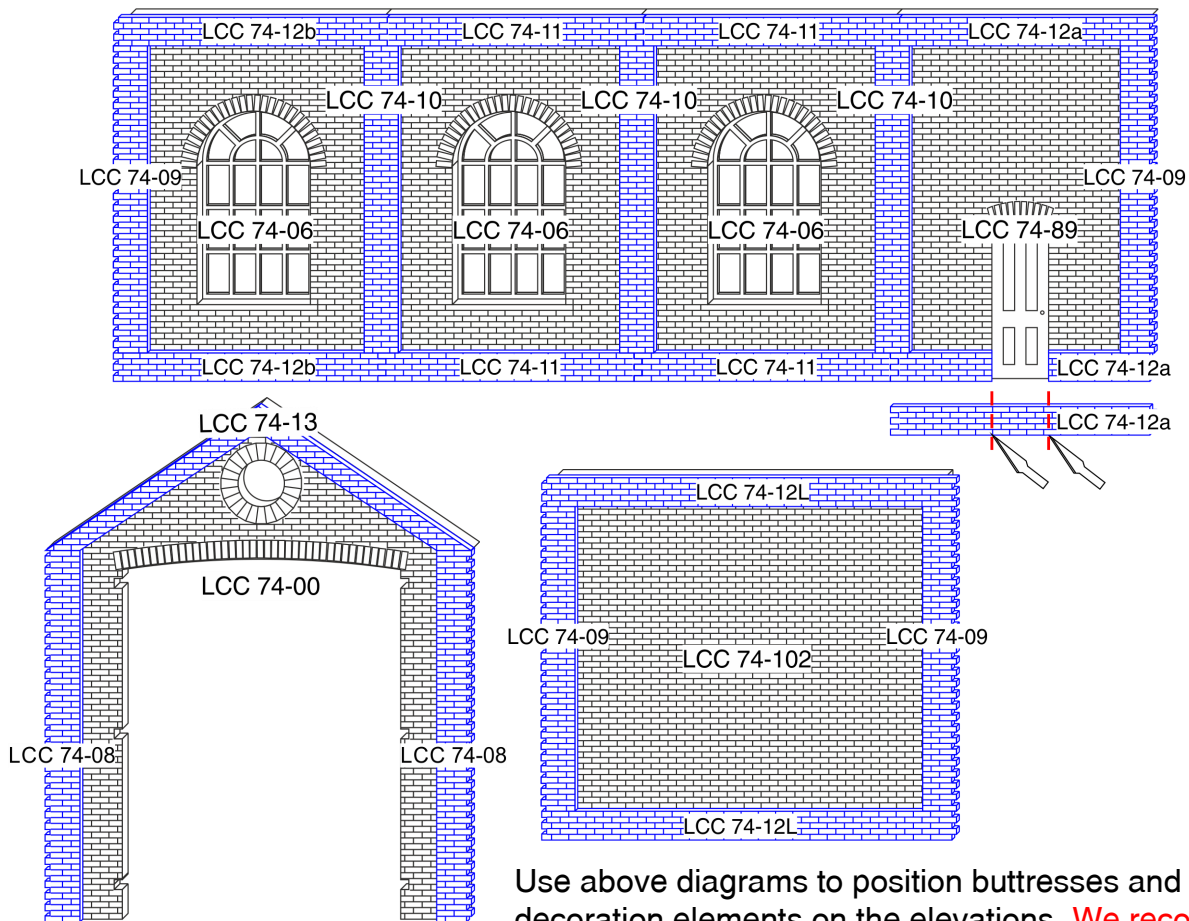

Use above diagrams to position buttresses and other decoration elements on the elevations. **We recommend to first assemble the shell of the building** composed of LCC 74-00, LCC 74-102, and LCC 74-06 etc. Substitute LCC 74-18 on one of the sides for LCC 74-89. Elements on the right and left edges of wall and gate panels should be protruding about quarter of a brick outside of the panel. Note that a space needs to be cut in one of LCC 74-12a elements for the door. This can be done after the parts is glued to LCC 74-89 by gently cutting it with a sharp hobby knife.

### CONNECTING WALL ELEMENTS

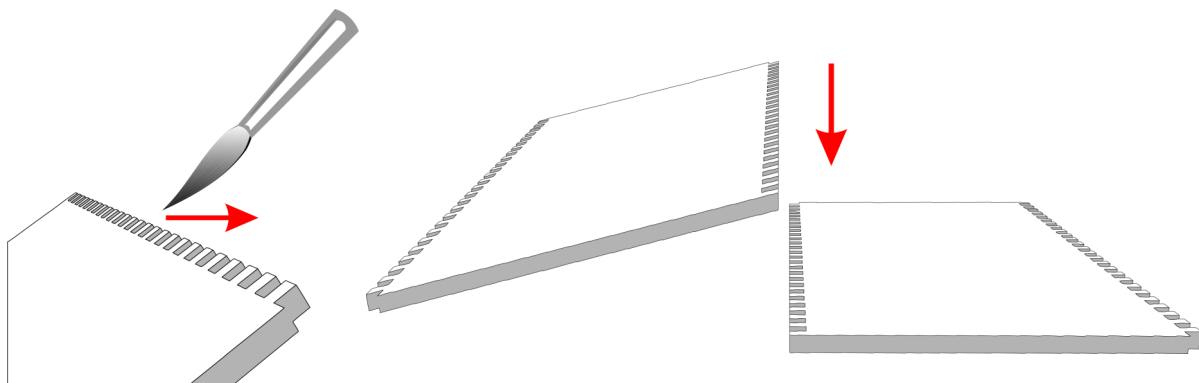

Recommended way of gluing parts together is to apply PVA glue to the interlocking bricks working from back of the part to the front. This ensures there will be no glue overflow on the front, visible side.

Then lay the part without glue on flat surface laying on its front (engraved side). Press the part with glue onto the part without glue. Gently push parts together from sides to close the gap.

## WATER TANK AND INNER SUPPORTS

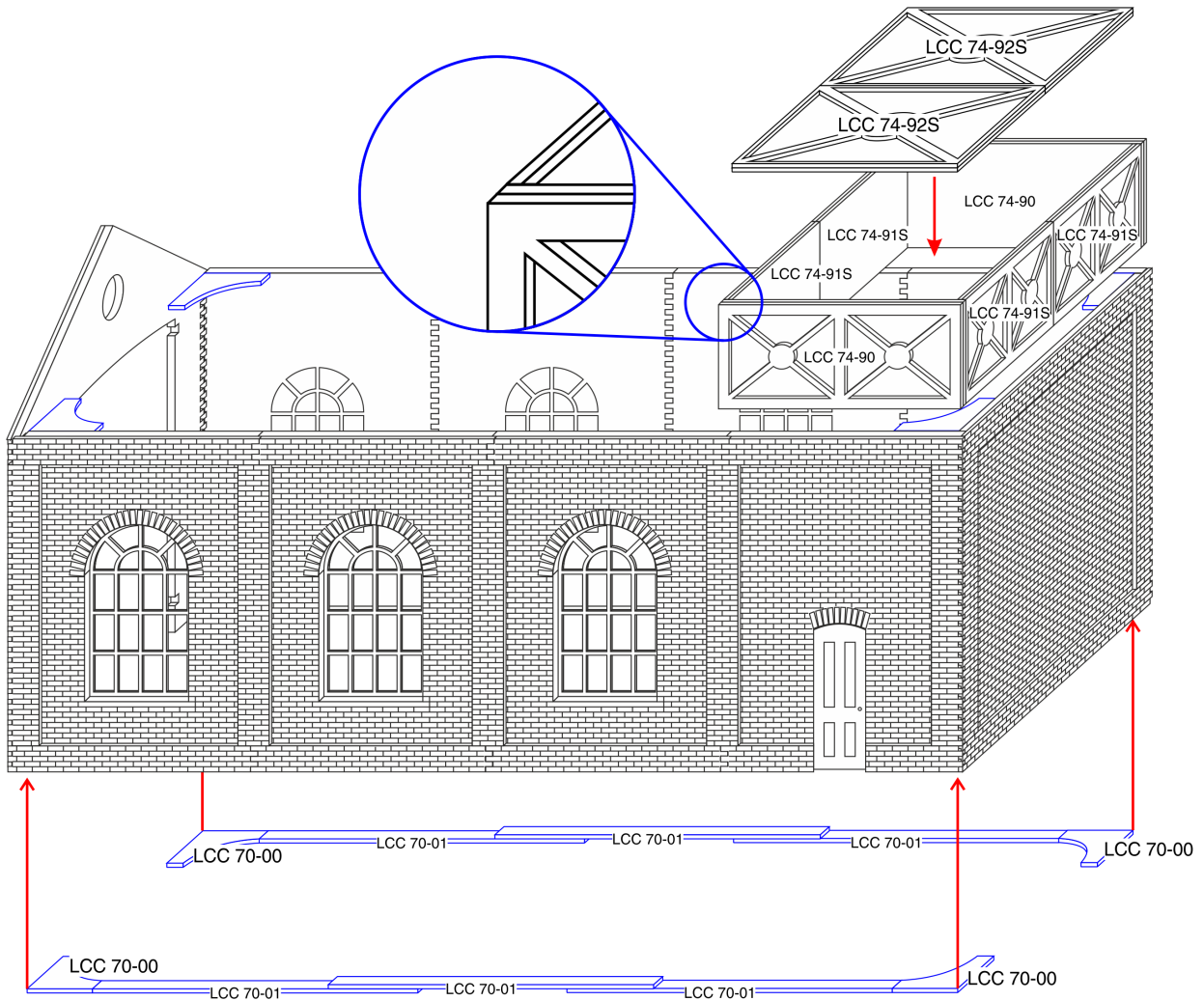

After the shell have been assembled and all of the decoration pieces shown on previous page have been glued to the shell assemble the water tank and glue it to the back end of the shed. Water tank should be glued to the engine shed in such a way that the protruding decoration elements are even on all three sides.

LCC 70-00 and LCC 70-01 are optional parts that can be used to stiffen the walls and corners.

## ROOF STRUTS

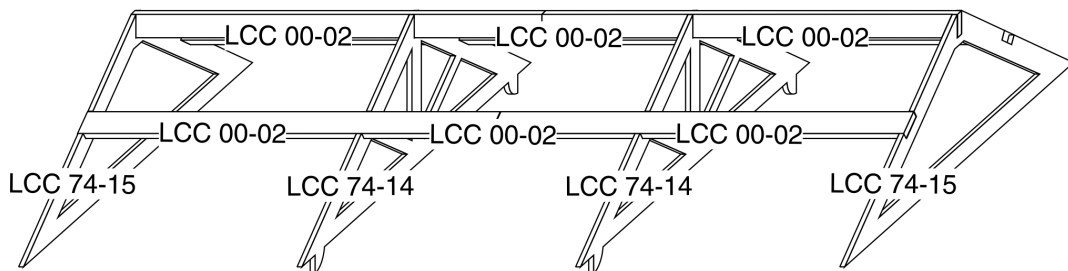
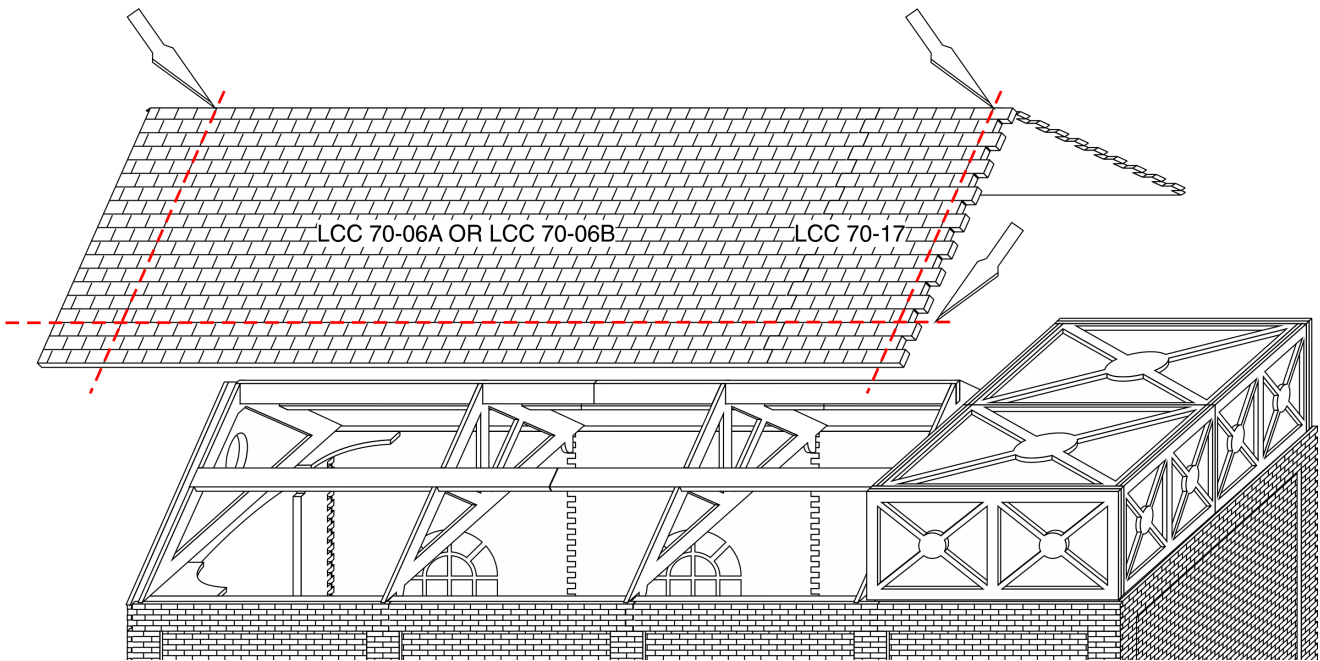

Diagram above shows the roof truss structure as it was assembled outside of the engine shed. We recommend not to assemble it outside of the shell unless a removable roof is required.

LCC 74-15 should be glued to the back of LCC 74-00 flush with top gable edges. One of LCC 74-15 should also be glued to the water tank, care should be taken to make sure it is centred.

LCC 74-14 can be glued in any position but we recommend to position them over the joints in LCC 74-06. Use diagram from next page for reference.

## ROOF PANELS



Glue LCC 70-17 to each LCC 70-06A and LCC 70-06B to form the roof tiles panel blanks. Leave to dry.

Measure the exact length required for the roof and cut to size. Roof tile panels should be flush with LCC 74-13 and butted firmly to the water tank.

## ROOF VENTILATION AND RIDGE TILES AND GATES

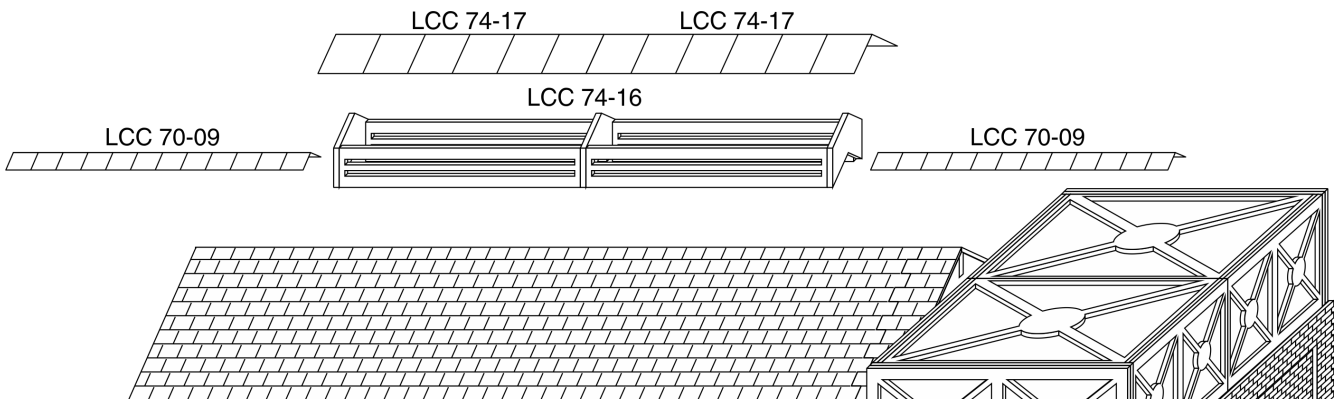

Last few steps in the assembly is to glue the roof vents to the ridge of the roof. Cut out all of the parts from LCC 74-16 and assemble as shown on diagram above. Note that the engraved edge of roof vent walls should be facing inwards. This allows roof vents to sit closer to the roof tiles and look neater. LCC 74-17 need to be trimmed to length same as LCC 70-09 ridge tiles. Fold both in half, offer to the corresponding parts and trim to length.

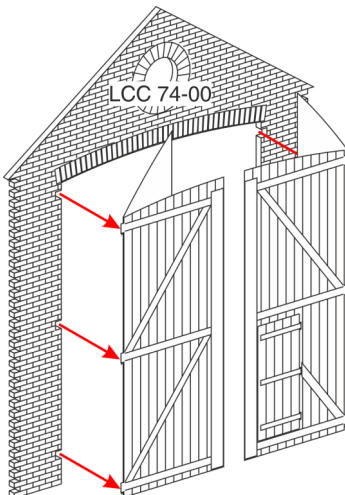

Last step in the assembly process is to glue the gates in. Fold gate panels in half along the hinges making sure all of the edges are flush with each other. Lastly glue the gates into LCC 74-00 in desired position. It is possible to install hinges for the gates by first threading a length of wire through the hinges and then sinking it into LCC 74-00.